

<b>DTC</b>	<b>B1800/51</b>	<b>Short in Driver Side Squib Circuit</b>
<b>DTC</b>	<b>B1801/51</b>	<b>Open in Driver Side Squib Circuit</b>
<b>DTC</b>	<b>B1802/51</b>	<b>Short to GND in Driver Side Squib Circuit</b>
<b>DTC</b>	<b>B1803/51</b>	<b>Short to B+ in Driver Side Squib Circuit</b>

## DESCRIPTION

The driver side squib circuit consists of the center airbag sensor assembly, the spiral cable and the steering pad.

The circuit signals the SRS to deploy when deployment conditions are met.

These DTCs are set when a malfunction is detected in the driver side squib circuit.

<b>DTC No.</b>	<b>DTC Detecting Condition</b>	<b>Trouble Area</b>
B1800/51	<ul style="list-style-type: none"> <li>The center airbag sensor assembly receives a line short circuit signal in the driver side squib circuit for 2 seconds.</li> <li>Driver side squib malfunction</li> <li>Spiral cable malfunction</li> <li>Center airbag sensor assembly malfunction</li> </ul>	<ul style="list-style-type: none"> <li>Instrument panel wire</li> <li>Spiral cable</li> <li>Steering pad (Driver side squib)</li> <li>Center airbag sensor assembly</li> </ul>
B1801/51	<ul style="list-style-type: none"> <li>The center airbag sensor assembly receives a line short circuit signal in the driver side squib circuit for 2 seconds.</li> <li>Driver side squib malfunction</li> <li>Spiral cable malfunction</li> <li>Center airbag sensor assembly malfunction</li> </ul>	<ul style="list-style-type: none"> <li>Instrument panel wire</li> <li>Spiral cable</li> <li>Steering pad (Driver side squib)</li> <li>Center airbag sensor assembly</li> </ul>
B1802/51	<ul style="list-style-type: none"> <li>The center airbag sensor assembly receives a line short circuit to ground signal in the driver side squib circuit for 0.5 seconds.</li> <li>Driver side squib malfunction</li> <li>Spiral cable malfunction</li> <li>Center airbag sensor assembly malfunction</li> </ul>	<ul style="list-style-type: none"> <li>Instrument panel wire</li> <li>Spiral cable</li> <li>Steering pad (Driver side squib)</li> <li>Center airbag sensor assembly</li> </ul>
B1803/51	<ul style="list-style-type: none"> <li>The center airbag sensor assembly receives a line short circuit to B+ signal in the driver side squib circuit for 0.5 seconds.</li> <li>Driver side squib malfunction</li> <li>Spiral cable malfunction</li> <li>Center airbag sensor assembly malfunction</li> </ul>	<ul style="list-style-type: none"> <li>Instrument panel wire</li> <li>Spiral cable</li> <li>Steering pad (Driver side squib)</li> <li>Center airbag sensor assembly</li> </ul>

## WIRING DIAGRAM

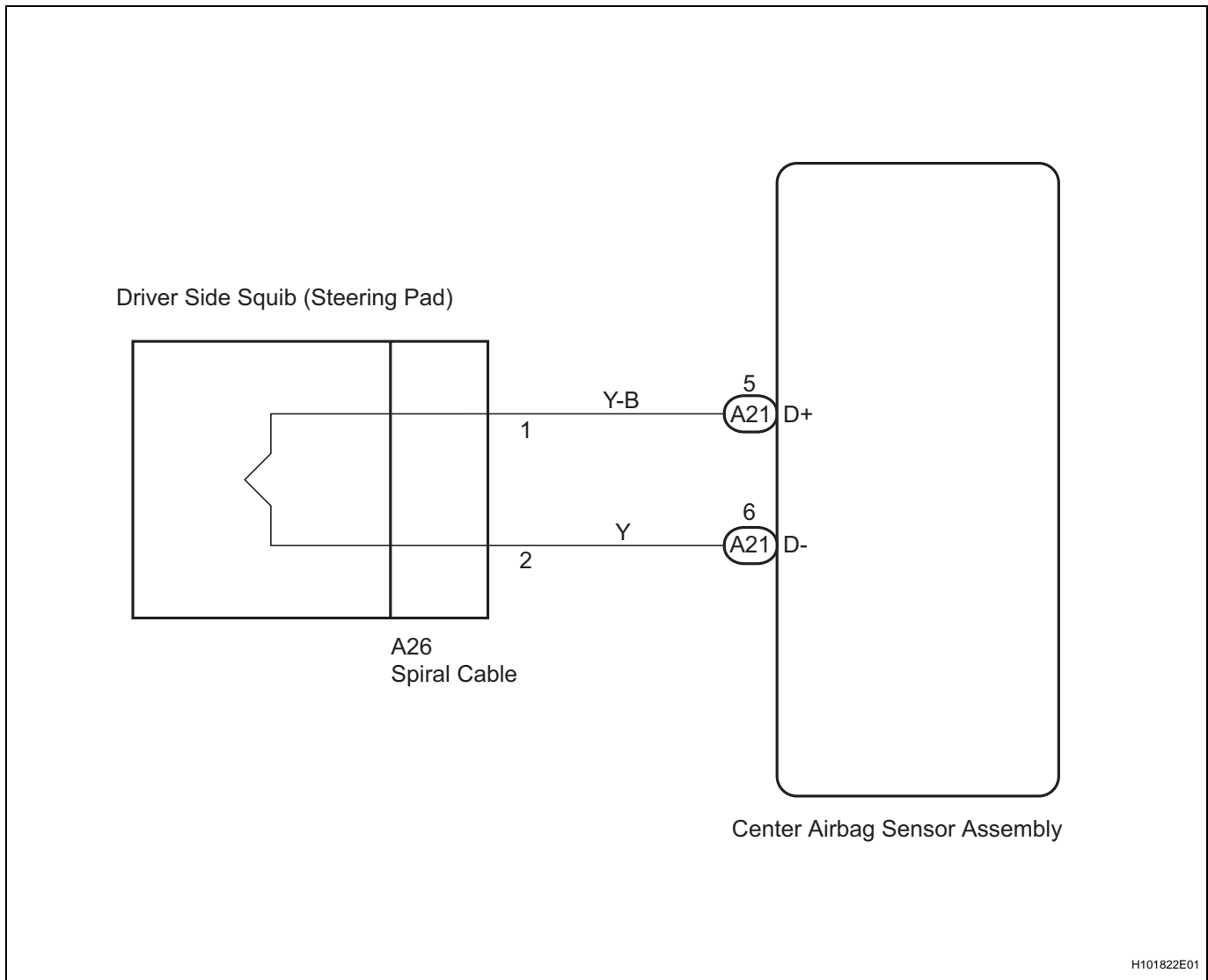
**CAUTION:**

**In order to prevent unexpected airbag deployment, disconnect the following connectors before inspecting parts such as wire harnesses, if the application of tester probes to the center airbag sensor assembly connector is necessary.**

- (a) Turn the ignition switch to the LOCK position.
- (b) Disconnect the negative (-) terminal cable from the battery and wait for at least 90 seconds.
- (c) Disconnect the connectors from the center airbag sensor assembly.
- (d) Disconnect the connectors from the steering pad.
- (e) Disconnect the connector from the front passenger airbag assembly.
- (f) Disconnect the connector from the front seat airbag assembly LH.
- (g) Disconnect the connector from the front seat airbag assembly RH.

**HINT:**

Skip the following steps if side and curtain shield airbags are not fitted.

- (h) Disconnect the connector from the curtain shield airbag assembly LH.
- (i) Disconnect the connector from the curtain shield airbag assembly RH.
- (j) Disconnect the connector from the front seat outer belt assembly LH.
- (k) Disconnect the connector from the front seat outer belt assembly RH.

**1 CHECK DTC**

- (a) Proceed to the appropriate step according to DTC readings.
  - (1) If using the intelligent tester (read the 5-digit DTCs):  
Using the intelligent tester, check for DTCs (See page RS-34).

**Result**

Result	Proceed to
DTC B1800 is output.	A
DTC B1801 is output.	B
DTC B1802 is output.	C
DTC B1803 is output.	D

- (2) If not using the intelligent tester (read the 2-digit DTCs):  
Check for DTCs (See page RS-34).

**Result**

Result	Proceed to
DTC 51 is output.	E

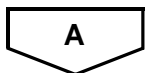
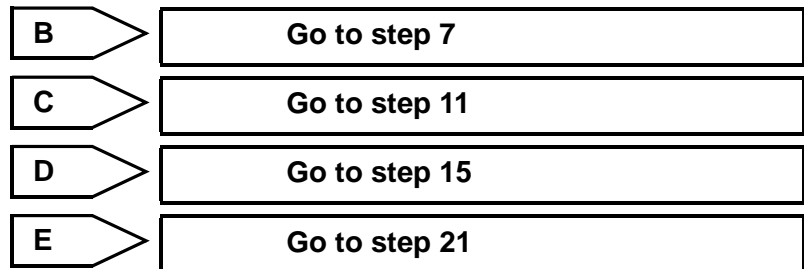

**2 CHECK CONNECTOR**

- (a) Turn the ignition switch to the LOCK position.
- (b) Disconnect the negative (-) terminal cable from the battery, and wait for at least 90 seconds.
- (c) Check that the spiral cable connectors (on the steering pad side) are not damaged.

**OK:**

The lock button is not disengaged, and the claw of the lock is not deformed or damaged.



**3 CHECK CONNECTION OF CONNECTORS**

- (a) Check that the connectors are properly connected to the center airbag sensor assembly and the spiral cable.

**OK:**

The connectors are properly connected.

**NG** **CONNECT CONNECTORS**

**OK**

**4 CHECK SPIRAL CABLE (FOR SHORT)**

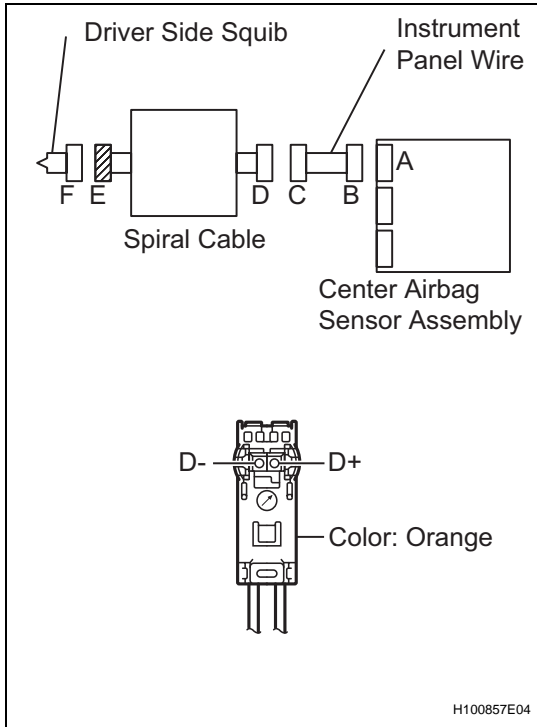

- (a) Disconnect the spiral cable connectors from the instrument panel wire and steering pad.
  - (b) Release the activation prevention mechanism built into connector D (See page [RS-28](#)).
  - (c) Measure the resistance.
- Standard resistance**

Tester Connection	Condition	Specified Condition
D+ - D-	Always	1 MΩ or Higher

**NG** **REPLACE SPIRAL CABLE**

**OK**

**5 CHECK INSTRUMENT PANEL WIRE (FOR SHORT)**

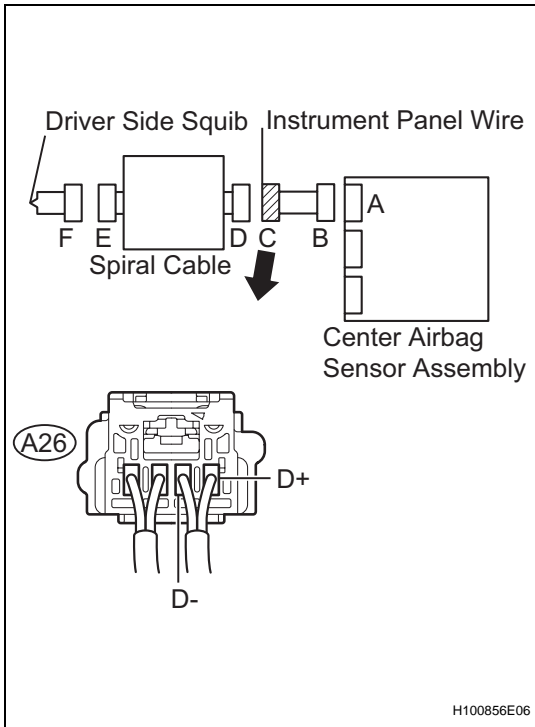

- (a) Disconnect the instrument panel wire connector from the center airbag sensor assembly.
- (b) Release the activation prevention mechanism built into connector B (See page RS-28).
- (c) Measure the resistance.

**Standard resistance**

Tester Connection	Condition	Specified Condition
A26-1 (D+) - A26-2 (D-)	Always	1 MΩ or Higher

**NG** REPAIR OR REPLACE INSTRUMENT PANEL WIRE

**OK**

**6 CHECK CENTER AIRBAG SENSOR ASSEMBLY**

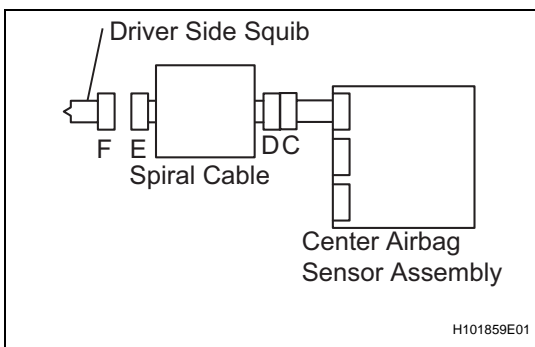

- (a) Connect the instrument panel wire connectors to the center airbag sensor assembly and spiral cable.
- (b) Connect the negative (-) terminal cable to the battery, and wait for at least 2 seconds.
- (c) Turn the ignition switch to the ON position, and wait for at least 60 seconds.
- (d) Clear any DTCs stored in the memory (See page RS-34).
- (e) Turn the ignition switch to the LOCK position.
- (f) Turn the ignition switch to the ON position, and wait for at least 60 seconds.
- (g) Check for DTCs (See page RS-34).

**OK:**  
**DTC B1800 is not output.**

**HINT:**  
DTCs other than B1800 may be output at this time, but they are not related to this check.

**NG**

**OK** Go to step 20

**REPLACE CENTER AIRBAG SENSOR ASSEMBLY**

**7 CHECK CONNECTOR**

- Turn the ignition switch to the LOCK position.
- Disconnect the negative (-) terminal cable from the battery, and wait for at least 90 seconds.
- Check that the spiral cable connectors (on the steering pad side) are not damaged.

**OK:**

The lock button is not disengaged, and the claw of the lock is not deformed or damaged.

**NG****REPLACE SPIRAL CABLE****OK****8 CHECK CONNECTION OF CONNECTORS**

- Check that the spiral cable connectors (on the steering pad side) are properly connected.

**OK:**

The connectors are properly connected.

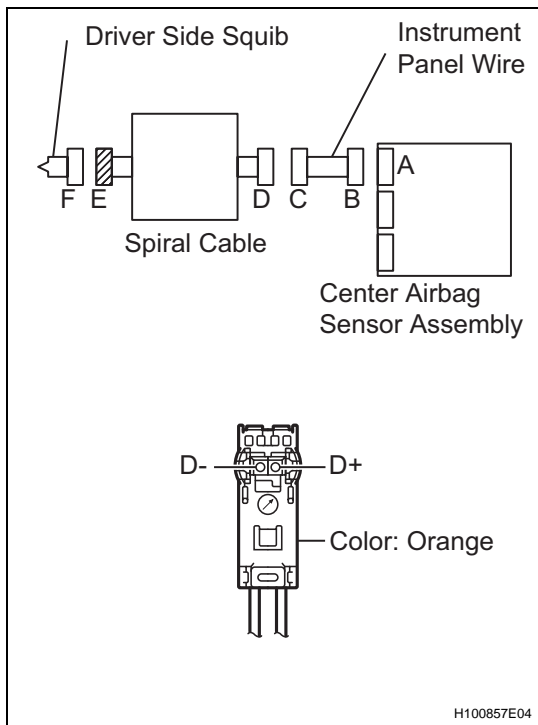
**NG****CONNECT CONNECTORS****OK****9 CHECK SPIRAL CABLE (FOR OPEN)**

- Disconnect the spiral cable connectors from the instrument panel wire and steering pad.

- Measure the resistance.

**Standard resistance**

Tester Connection	Condition	Specified Condition
D+ - D-	Always	Below 1 $\Omega$

**NG****REPLACE SPIRAL CABLE****OK**

**10 CHECK INSTRUMENT PANEL WIRE (FOR OPEN)**

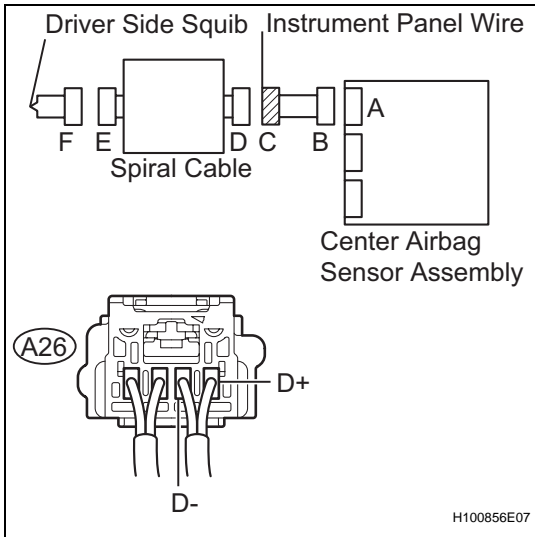

- (a) Disconnect the instrument panel wire connector from the center airbag sensor assembly.
  - (b) Measure the resistance.
- Standard resistance**

Tester Connection	Condition	Specified Condition
A26-1 (D+) - A26-2 (D-)	Always	Below 1 Ω

**OK** → **Go to step 19**

**NG**

**REPAIR OR REPLACE INSTRUMENT PANEL WIRE**

**11 CHECK CONNECTOR**

- (a) Turn the ignition switch to the LOCK position.
- (b) Disconnect the negative (-) terminal cable from the battery, and wait for at least 90 seconds.
- (c) Check that the spiral cable connectors (on the steering pad side) are not damaged.

**OK:**

The lock button is not disengaged, and the claw of the lock is not deformed or damaged.

**NG** → **REPLACE SPIRAL CABLE**

**OK**

**RS**

**12 CHECK CONNECTION OF CONNECTORS**

- (a) Check that the spiral cable connectors (on the steering pad side) are properly connected.

**OK:**

The connectors are properly connected.

**NG** → **CONNECT CONNECTORS**

**OK**

**13 CHECK SPIRAL CABLE (TO GROUND)**

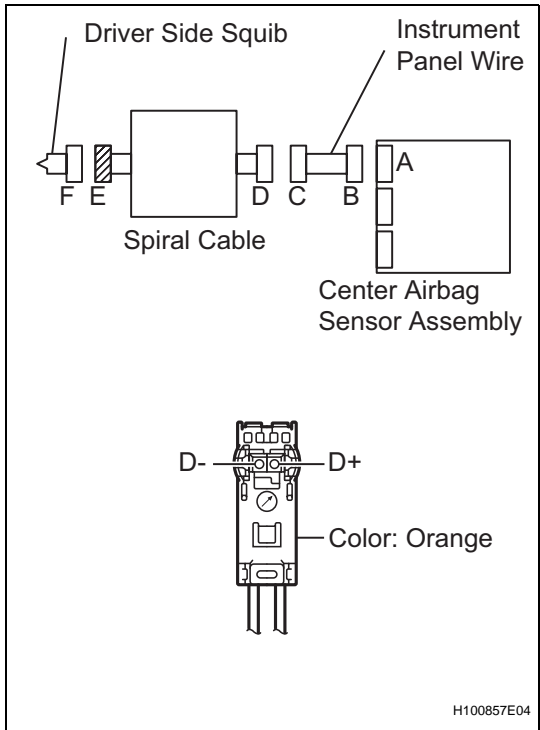

- (a) Disconnect the spiral cable connectors from the instrument panel wire and steering pad.
  - (b) Measure the resistance.
- Standard resistance**

Tester Connection	Condition	Specified Condition
D+ - Body ground	Always	1 MΩ or Higher
D- - Body ground	Always	1 MΩ or Higher

**NG** → **REPLACE SPIRAL CABLE**

**OK**

**14 CHECK INSTRUMENT PANEL WIRE (TO GROUND)**

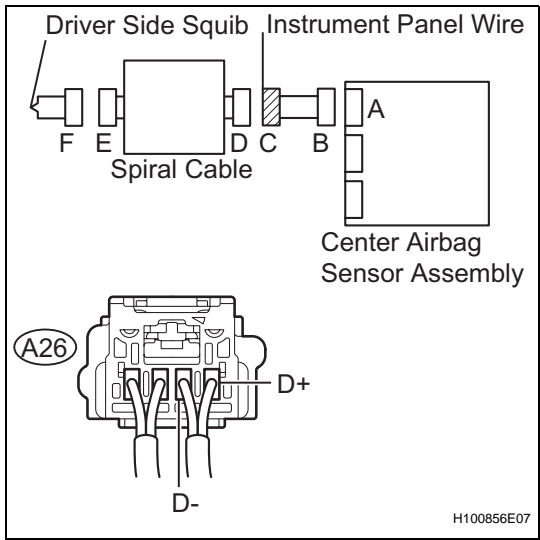

- (a) Disconnect the instrument panel wire connector from the center airbag sensor assembly.
  - (b) Measure the resistance.
- Standard resistance**

Tester Connection	Condition	Specified Condition
A26-1 (D+) - Body ground	Always	1 MΩ or Higher
A26-2 (D-) - Body ground	Always	1 MΩ or Higher

**OK** → **Go to step 19**

**NG**

**REPAIR OR REPLACE INSTRUMENT PANEL WIRE**

**RS**

**15 CHECK CONNECTOR**

- (a) Turn the ignition switch to the LOCK position.
- (b) Disconnect the negative (-) terminal cable from the battery, and wait for at least 90 seconds.
- (c) Check that the spiral cable connectors (on the steering pad side) are not damaged.

**OK:**

The lock button is not disengaged, and the claw of the lock is not deformed or damaged.

**NG** → **REPLACE SPIRAL CABLE**

**OK**

**16 CHECK CONNECTION OF CONNECTORS**

- (a) Check that the spiral cable connectors (on the steering pad side) are properly connected.

**OK:**

The connectors are properly connected.

**NG** → **CONNECT CONNECTORS**

**OK**

**17 CHECK SPIRAL CABLE (TO B+)**

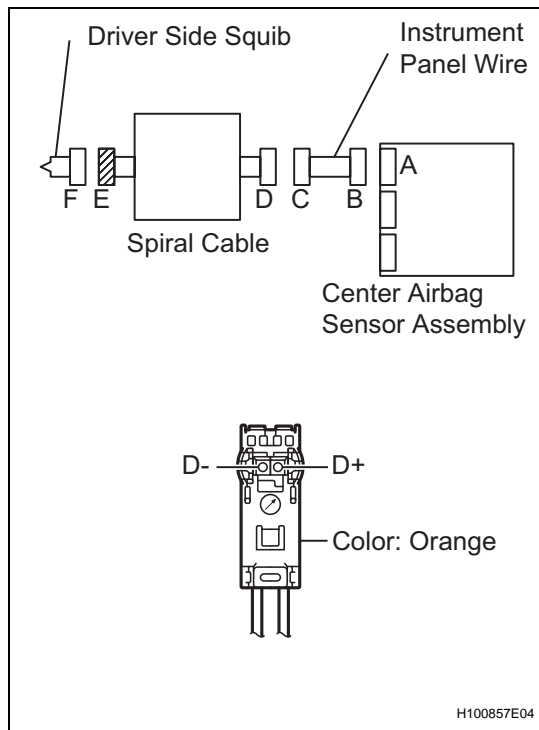

- (a) Disconnect the spiral cable connectors from the instrument panel wire and steering pad.
- (b) Connect the negative (-) terminal cable to the battery, and wait for at least 2 seconds.
- (c) Turn the ignition switch to the ON position.
- (d) Measure the voltage

**Standard voltage**

Tester Connection	Condition	Specified Condition
D+ - Body ground	Ignition switch ON	Below 1 V
D- - Body ground	Ignition switch ON	Below 1 V

**NG** → **REPLACE SPIRAL CABLE**

**OK**

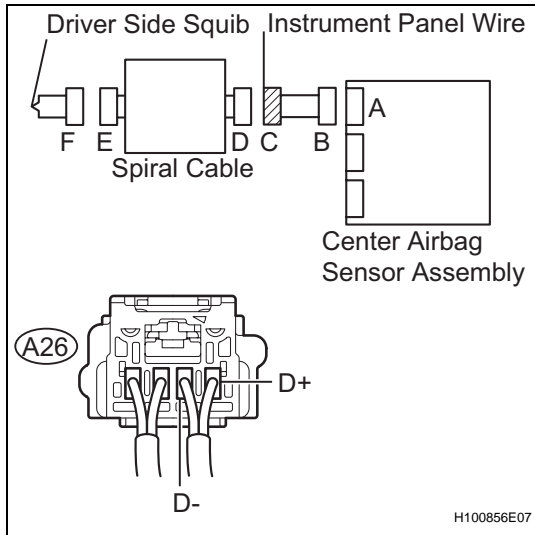
**18 CHECK INSTRUMENT PANEL WIRE (TO B+)**

- Turn the ignition switch to the LOCK position.
- Disconnect the negative (-) terminal cable from the battery, and wait for at least 90 seconds.
- Disconnect the instrument panel wire connector from the center airbag sensor assembly.
- Connect the negative (-) terminal cable to the battery, and wait for at least 2 seconds.
- Turn the ignition switch to the ON position.
- Measure the voltage.

**Standard voltage**

Tester Connection	Condition	Specified Condition
A26-1 (D+) - Body ground	Ignition switch ON	Below 1 V
A26-2 (D-) - Body ground	Ignition switch ON	Below 1 V

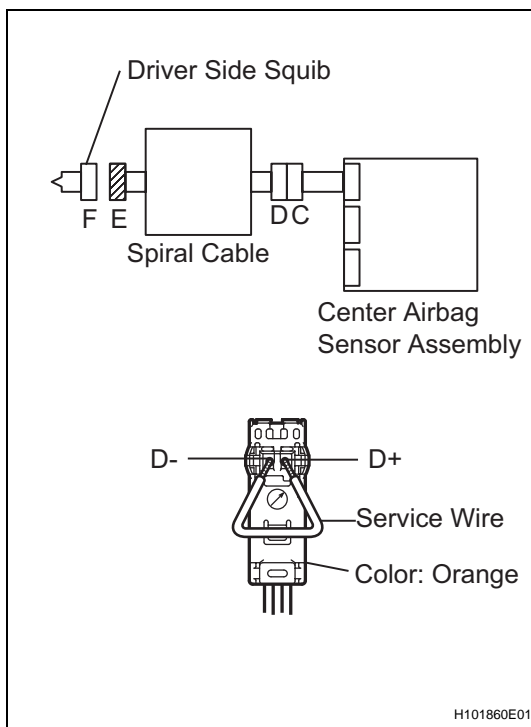
**NG****REPAIR OR REPLACE INSTRUMENT PANEL WIRE****OK****19 CHECK CENTER AIRBAG SENSOR ASSEMBLY****HINT:**

If continuing from step 18, begin from (a). If continuing from any other step, begin from (c).

- Turn the ignition switch to the LOCK position.
- Disconnect the negative (-) terminal cable from the battery, and wait for at least 90 seconds.
- Connect the instrument panel wire connectors to the center airbag sensor assembly.
- Using a service wire, connect D+ and D- of connector E.

**NOTICE:**

- Twist the end of the service wire in order to insert it into the connector.
  - Do not forcibly insert the twisted service wire into the terminals of the connector when connecting.
- Connect the negative (-) terminal cable to the battery, and wait for at least 2 seconds.
  - Turn the ignition switch to the ON position, and wait for at least 60 seconds.
  - Clear any DTCs stored in the memory (See page [RS-34](#)).
  - Turn the ignition switch to the LOCK position.
  - Turn the ignition switch to the ON position, and wait for at least 60 seconds.
  - Check for DTCs (See page [RS-34](#)).

**OK:**

**DTCs B1801, B1802 and B1803 are not output.**

HINT:

DTCs other than B1801, B1802 or B1803 may be output at this time, but they are not related to this check.

**NG** **REPLACE CENTER AIRBAG SENSOR ASSEMBLY**

**OK**

**20 REPLACE STEERING PAD (DRIVE SIDE SQUIB)**

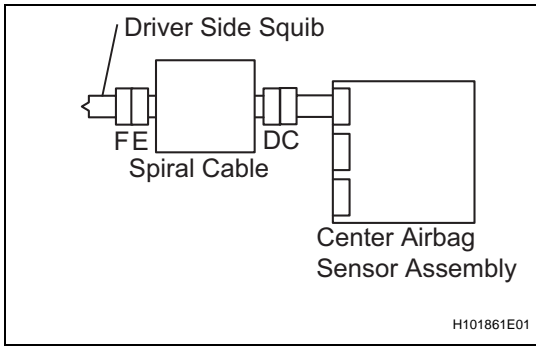

HINT:

If continuing from step 19, begin from (c). If continuing from any other step, being from (a).

- (a) Turn the ignition switch to the LOCK position.
- (b) Disconnect the negative (-) terminal cable from the battery, and wait for at least 90 seconds.
- (c) Disconnect the service wire from connector E.
- (d) Connect the connectors to the steering pad.
- (e) Connect the negative (-) terminal cable to the battery, and wait for at least 2 seconds.
- (f) Turn the ignition switch to the ON position, and wait for at least 60 seconds.
- (g) Clear any DTCs stored in the memory (See page RS-34).
- (h) Turn the ignition switch to the LOCK position.
- (i) Turn the ignition switch to the ON position, and wait for at least 60 seconds.
- (j) Check for DTCs (See page RS-34).

**OK:**

**DTCs B1800, B1801, B1802 and B1803 are not output.**

HINT:

DTCs other than B1800, B1801, B1802 or B1803 may be output at this time, but they are not related to this check.

**NG** **REPLACE STEERING PAD**

**OK**

**OTHERS USE SIMULATION METHOD TO CHECK**

**21 CHECK CONNECTOR**

- (a) Turn the ignition switch to the LOCK position.
- (b) Disconnect the negative (-) terminal cable from the battery, and wait for at least 90 seconds.
- (c) Check that the spiral cable connectors (on the steering pad side) are not damaged.

**OK:**

**The lock button is not disengaged, or the claw of the lock is not deformed or damaged.**

**NG** REPLACE SPIRAL CABLE

**OK**

**22 CHECK CONNECTORS**

- (a) Check that the spiral cable connectors (on the steering pad side) are properly connected.

**OK:**

The connectors are properly connected.

**NG** CONNECT CONNECTORS

**OK**

**23 CHECK SPIRAL CABLE**

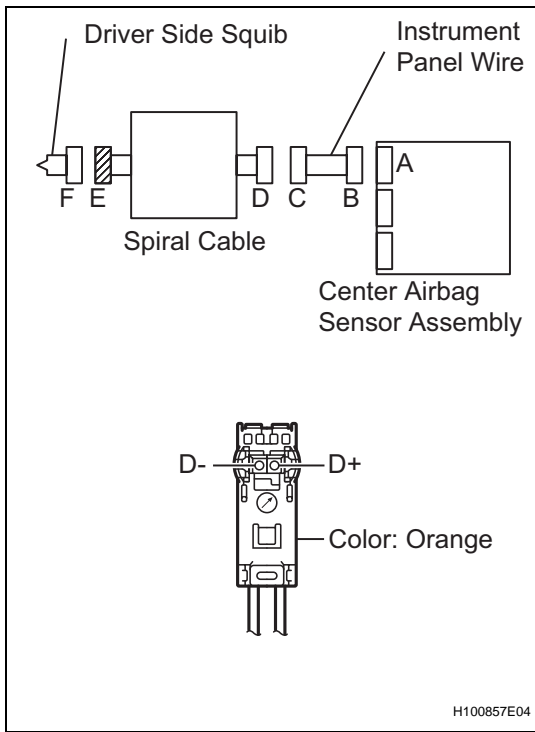

- (a) Disconnect the spiral cable connectors from the instrument panel wire and steering pad.
- (b) Connect the negative (-) terminal cable to the battery, and wait for at least 2 seconds.
- (c) Turn the ignition switch to the ON position.
- (d) Measure the voltage.

**Standard voltage**

Tester Connection	Condition	Specified Condition
D+ - Body ground	Ignition switch ON	Below 1 V
D- - Body ground	Ignition switch ON	Below 1 V

- (e) Turn the ignition switch to the LOCK position.
- (f) Disconnect the negative (-) terminal cable from the battery, and wait for at least 90 seconds.
- (g) Measure the resistance.

**Standard resistance**

Tester Connection	Condition	Specified Condition
D+ - D-	Always	Below 1 Ω
D+ - Body ground	Always	1 MΩ or Higher
D- - Body ground	Always	1 MΩ or Higher

- (h) Release the activation prevention mechanism built into connector D (See page RS-28).

- (i) Measure the resistance.

**Standard resistance**

Tester Connection	Condition	Specified Condition
D+ - D-	Always	1 MΩ or Higher

**NG** REPLACE SPIRAL CABLE

**OK**

**24 CHECK INSTRUMENT PANEL WIRE**

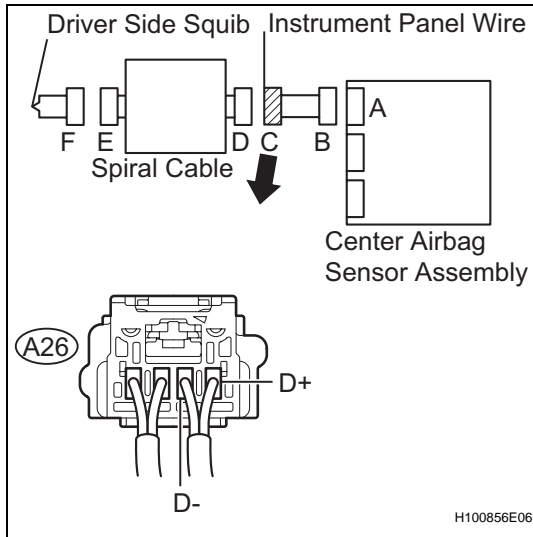

- (a) Restore the released activation prevention mechanism of connector B to the original condition.
- (b) Disconnect the instrument panel wire connector from the center airbag sensor assembly.
- (c) Connect the negative (-) terminal cable to the battery, and wait for at least 2 seconds.
- (d) Turn the ignition switch to the ON position.
- (e) Measure the voltage.

**Standard voltage**

Tester Connection	Condition	Specified Condition
A26-1 (D+) - Body ground	Ignition switch ON	Below 1 V
A26-2 (D-) - Body ground	Ignition switch ON	Below 1 V

- (f) Turn the ignition switch to the LOCK position.
- (g) Disconnect the negative (-) terminal cable from the battery, and wait for at least 90 seconds.
- (h) Measure the resistance.

**Standard resistance**

Tester Connection	Condition	Specified Condition
A26-1 (D+) - A26-2 (D-)	Always	Below 1 Ω
A26-1 (D+) - Body ground	Always	1 MΩ or Higher
A26-2 (D-) - Body ground	Always	1 MΩ or Higher

- (i) Release the activation prevention mechanism built into connector B (See page RS-28).
- (j) Measure the resistance.

**Standard resistance**

Tester Connection	Condition	Specified Condition
A26-1 (D+) - A26-2 (D-)	Always	1 MΩ or Higher

**NG REPAIR OR REPLACE INSTRUMENT PANEL WIRE**

**RS**

**OK**

## 25 CHECK CENTER AIRBAG SENSOR ASSEMBLY

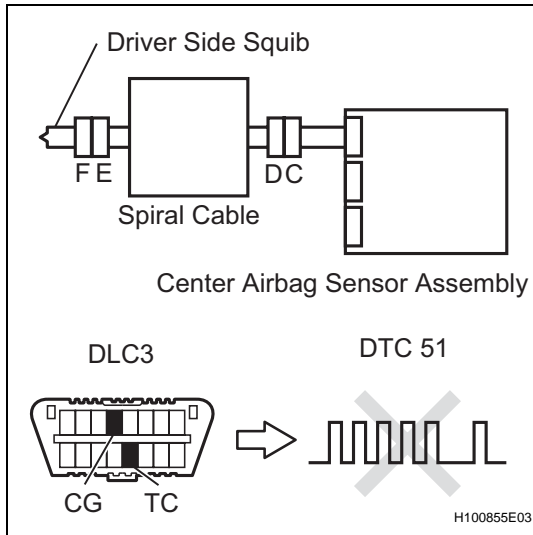

(a) Replace the steering pad (See page [RS-557](#)).

HINT:

Perform the inspection using parts from a normal vehicle when possible.

- (b) Connect the instrument panel wire to the airbag sensor assembly center and spiral cable.
- (c) Connect the connectors to the center airbag sensor assembly.
- (d) Connect the negative (-) terminal cable to the battery, and wait for at least 2 seconds.
- (e) Turn the ignition switch to the ON position, and wait for at least 60 seconds.
- (f) Clear any DTCs stored in the memory (See page [RS-34](#)).
- (g) Turn the ignition switch to the LOCK position.
- (h) Turn the ignition switch to the ON position, and wait for at least 60 seconds.
- (i) Check for DTCs (See page [RS-34](#)).

**OK:**

**DTC 51 is not output.**

HINT:

DTCs other than 51 may be output at this time, but they are not related to this check.

**NG**

**REPLACE CENTER AIRBAG SENSOR ASSEMBLY**

**OK**

**END**